

Aviation Fabricators
805 North Fourth Street
Clinton MO 64735

Document No: AF-569
Revision: (IR)
Date: August 2, 2013

INSTRUCTIONS FOR CONTINUED AIRWORTHINESS

For

3 Place Side Facing Divan Installations

Document No.: AF-569

Revision "IR"

Revision Date: 08/02/13

Applicable to:

**Hawker Beechcraft 65, A65, 65-80, 65-A80, 65-B80, 65-90, 65-A90, B90, C90, E90,
F90, 100, A100, B100, 200, 200C, 200CT, 200T, A200, A200C, A200CT, B200,
B200C, B200CT, B200T, 300, B300, B300C, 300LW Series Aircraft**

Modified by FAA STC's SA2349SW

The information in the Instruction for Continued Airworthiness is FAA accepted material and complies with 14 CFR 23.1529, Instructions for Continued Airworthiness. It supersedes or adds to that provided in the Maintenance Manual for the Hawker Beechcraft 65, 90, 100, 200, and 300 Series Aircraft, only where covered in the items contained herein. For limitations and procedures not contained in the Supplement, consult the Component Maintenance Manual, or other approved airplane data.

REVISION PAGE

Document Title: Instructions for Continued Airworthiness

Updates to the ICA will be made by Aviation Fabricators Inc. Updates will be listed in the log of revisions and the effective pages will be listed below.

Log of Revisions				
REV. NO.	EFFECTED PAGE(S)	DESCRIPTION	DATE	APPROVED BY
IR	All	Initial Release	08-02-13	JRL

Per the requirement of Appendix G of 14 CFR Part 23 paragraph G23.1 (c), the changes made to the ICA by the applicant will be distributed via mail by means of paper copy.

TABLE OF CONTENTS

INSTRUCTIONS FOR CONTINUED AIRWORTHINESS	1
REVISION PAGE	2
TABLE OF CONTENTS	3
1.0 INTRODUCTION	5
2.0 INSPECTION REQUIREMENTS AND OVERHAUL SCHEDULE	9
3.0 DIMENSION AND ACCESS	11
4.0 LIFTING AND SHORING	11
5.0 LEVELING AND WEIGHING	11
6.0 TOWING AND TAXIING	11
7.0 PARKING AND MOORING	11
8.0 PLACARDS AND MARKINGS	12
9.0 SERVICE INFORMATION	13
10.0 AIRWORTHINESS LIMITATIONS	14
11.0 TROUBLESHOOTING	14

ABBREVIATIONS AND DEFINITIONS

Abbreviations	Definitions
AML	FAA Approved Model List (AML)
Detailed Inspection (DET)	An intensive examination of a specific item, installation or assembly to detect damage, failure or irregularity. Available lighting is normally supplemented with a direct source of good lighting at an intensity deemed appropriate. Inspection aids such as mirrors, magnifying lenses, etc. may be necessary. Surface cleaning and elaborate access procedures may be required.
FAA	Federal Aviation Administration
FAA MIDO	FAA Manufacturing Inspection District Office
General Visual Inspection (GVI)	A visual examination of an interior or exterior area, installation or assembly to detect obvious damage, failure or irregularity. This level of inspection is made from within touching distance unless otherwise specified. A mirror may be necessary to enhance visual access to all exposed surfaces in the inspection area. This level of inspection is made under normally available lighting conditions such as daylight, hangar lighting, flashlight or droplight and may require removal or opening of access panels or doors. Stands, ladders or platforms may be required to gain proximity to the area being checked.
ICA	Instructions for Continued Airworthiness
Special Detailed Inspection (SDI)	An intensive examination of a specific item, installation , or assembly to detect damage, failure or irregularity. The examination is likely to make extensive use of specialized Inspection Techniques and/or equipment. Intricate cleaning and substantial access or disassembly procedure may be required.
STC	Supplemental Type Certificate

1.0 INTRODUCTION

The purpose of this Maintenance Manual Supplement and Instructions for Continued Airworthiness (ICA) is to provide the maintenance technician with the information necessary to ensure the continued airworthiness of the Aviation Fabricators 3 place divan installations, per installation numbers 32-0209K, 32-0260K, 32-0336K, 32-0337K, 32-0338K, and 32-0339K when installed in accordance with Aviation Fabricators design data included on STC Drawing List AF-153 and per Supplement Type Certificates (STC's) SA2349SW.

Modifications to an aircraft obligates the operator to include the maintenance information provided by this document into the operators aircraft Maintenance Manual and operator's aircraft scheduled maintenance program. This document defines supplementary maintenance operations and frequencies recommended by Aviation Fabricators Inc., to ensure the aircraft's airworthiness.

The information contained herein addresses the requirements specified in 14 CFR 23.1529, Instructions for Continued Airworthiness and supplements the basic Airplane Maintenance Manual only in those areas listed as pertains to the installation of the side facing divans, as installed per the Aviation Fabricator STC Drawing List AF-153. For limitations and procedures not contained in this supplement, consult the basic Airplane Maintenance Manual.

DATA

All information to support the continued airworthiness of this modification is contained in:

STC SA2349SW.

STC Drawing List: AF-153.

Installation: STC Drawing Lists: AF-153

Drawing AF-132 for p/n's 32-0209K, 32-0260K, 32-0336K,
32-0337K, 32-0338K, 32-0339K

Parts: Refer to p/n's 32-0209, 32-0260, 32-0336, 32-0337, 32-0338, and 32-0339 and respective drawings as listed on STC Drawing List AF-153.

The divan is a self-contained complete assembly that mounts in the cabin to the existing seat track, using standard fittings.

Design Change Control

All data and changes to the parts and assemblies will be tracked per STC Drawing List AF-153 Rev D or later approved revision.

Applicable Aircraft

Hawker Beechcraft 65, A65, 65-80, 65-A80, 65-B80, 65-90, 65-A90, B90, C90, E90, F90, 100, A100, B100, 200, 200C, 200CT, 200T, A200, A200C, A200CT, B200, B200C, B200CT, B200T, 300, B300, B300C, 300LW Series Aircraft

3 Place Divans

P/N's 32-0209 (shown), 32-0260, 32-0336, 32-0337, 32-0338, and 32-0339
Shown without top.

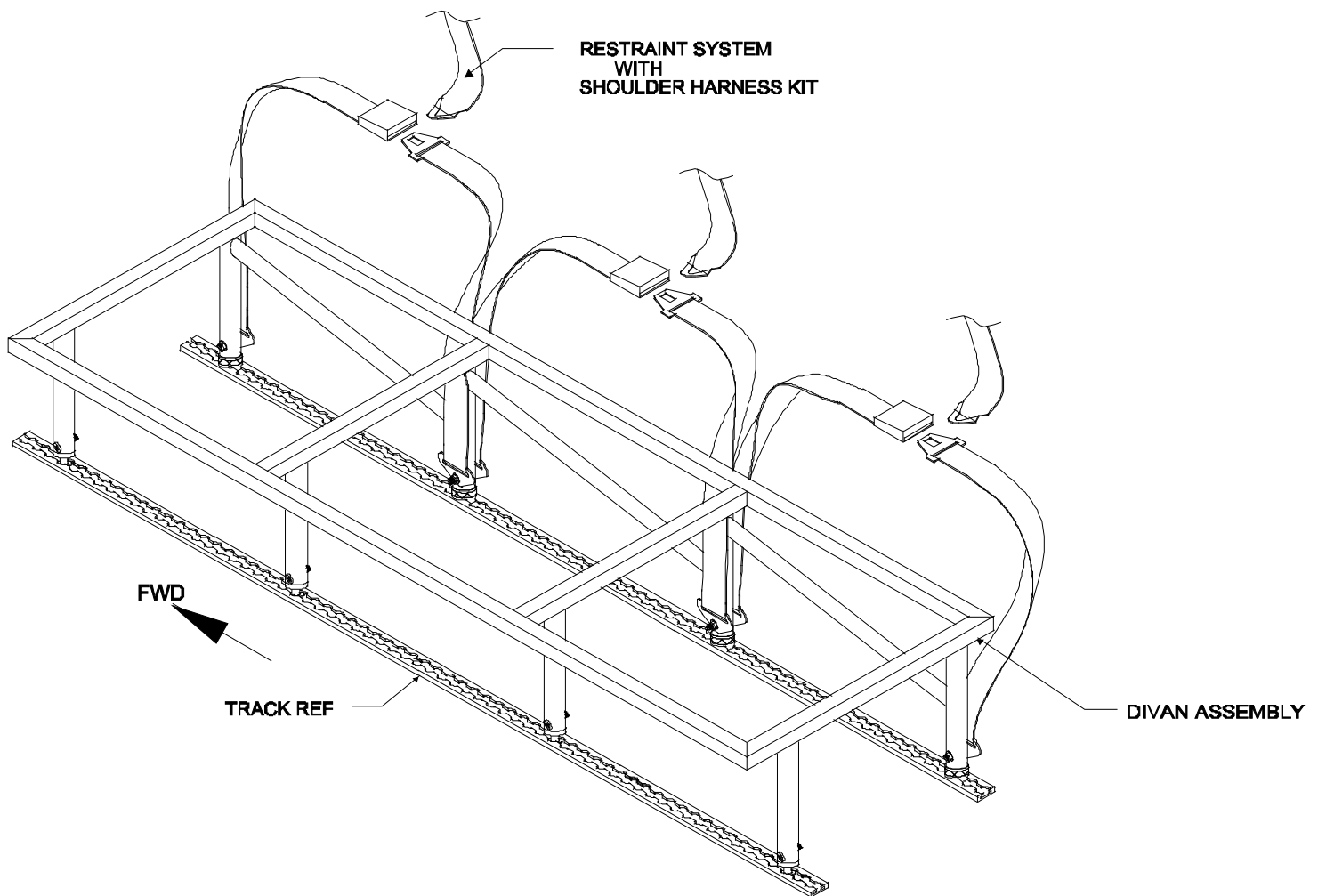

Figure 1.0A

Foot Installation and Seat Belt Attachment

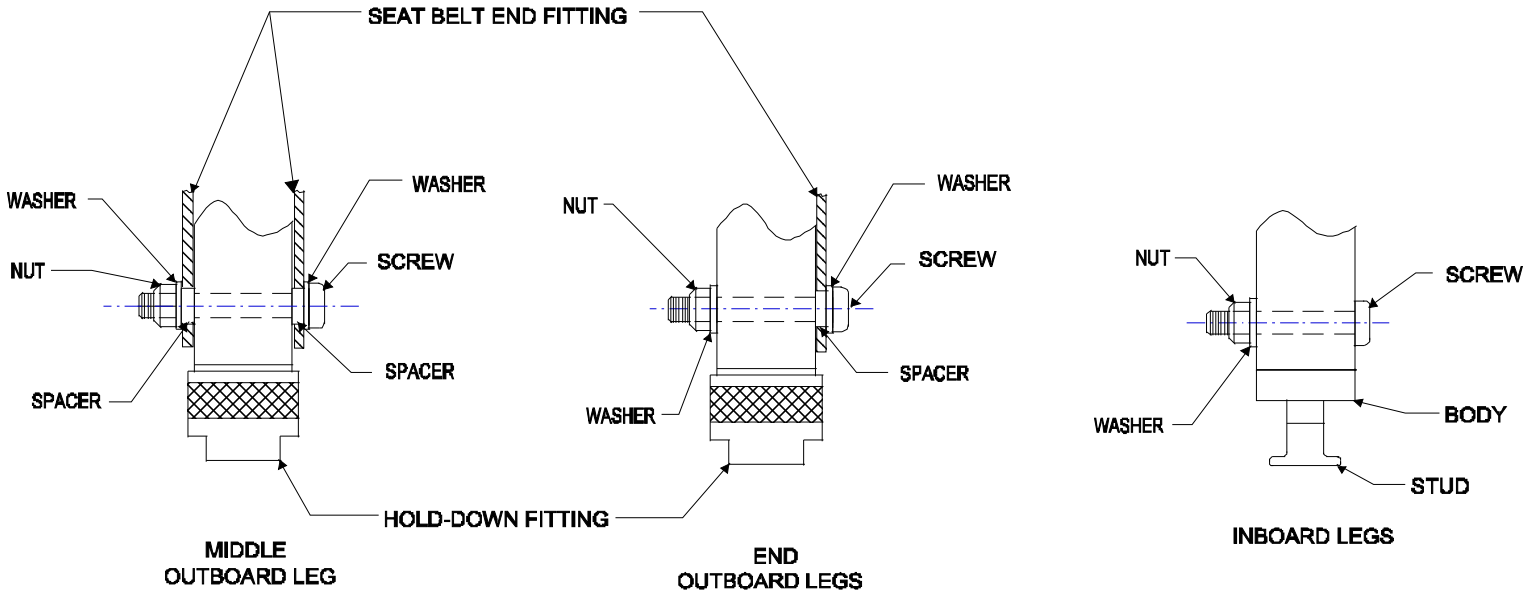

Figure 1.0B

Drawers

For P/N's 32-0239 & 32-0257

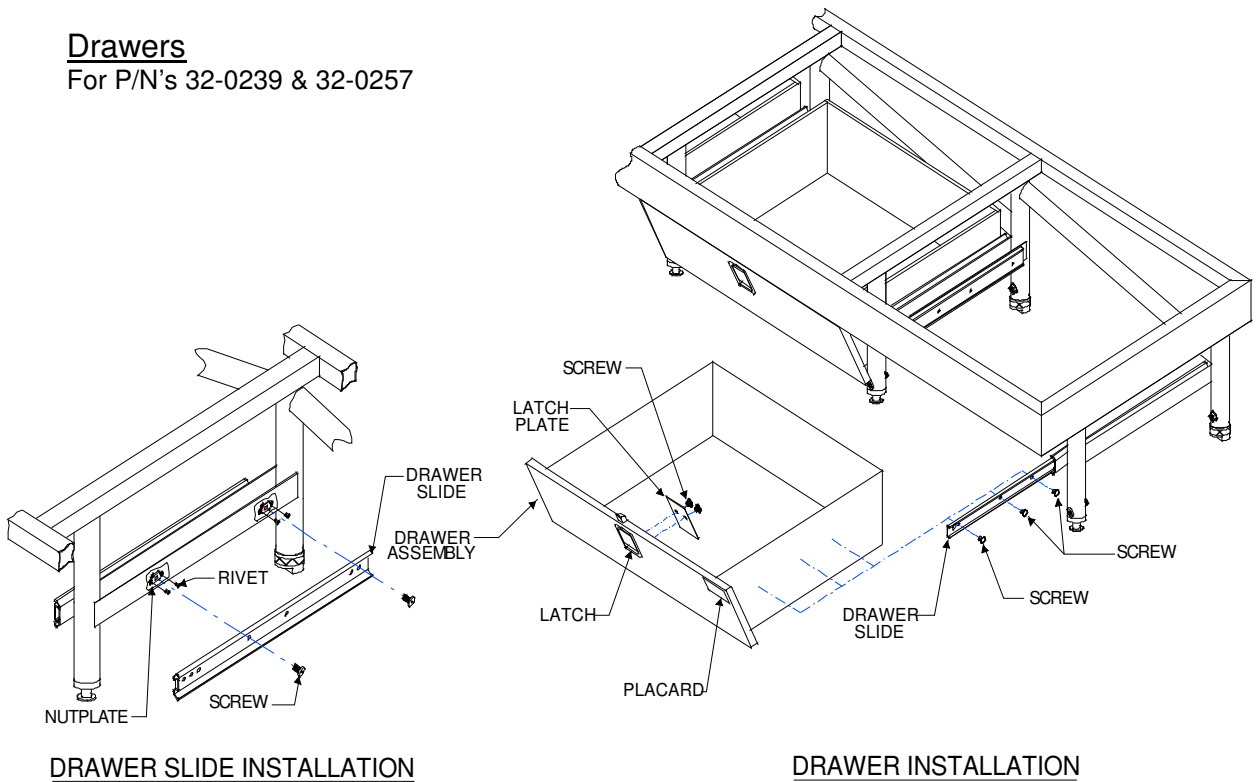

Figure 1.0C

Cushions

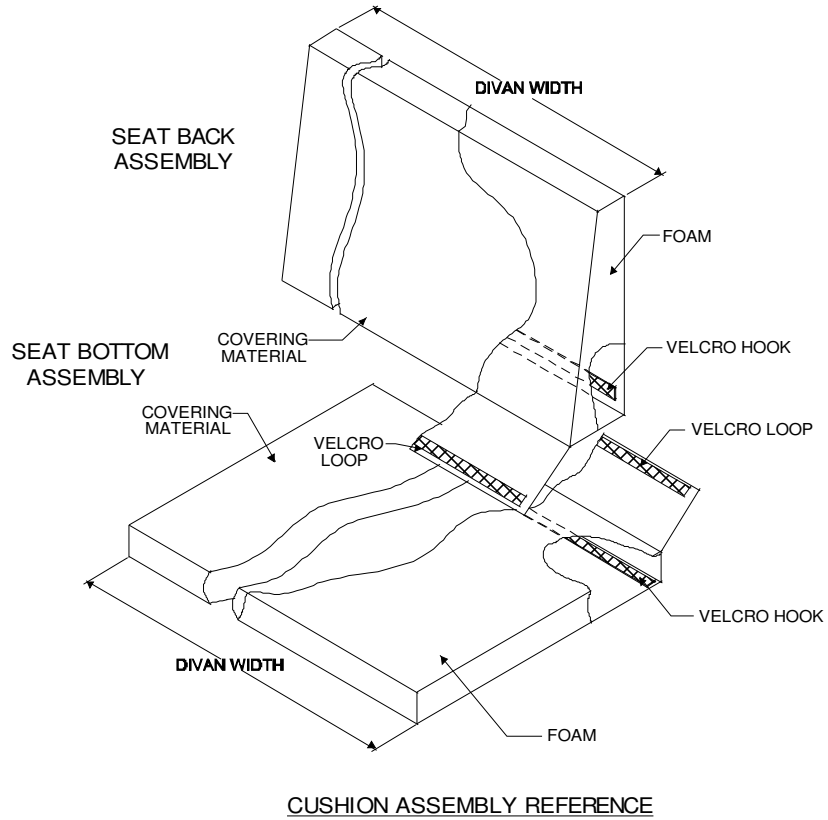

Figure 1.0D

Fwd Bulkhead Cushion

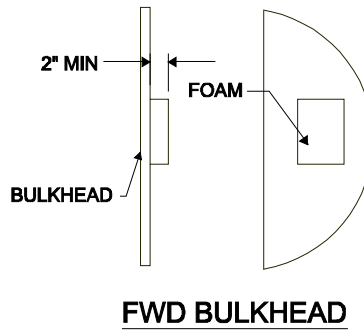

Figure 1.0E

2.0 INSPECTION REQUIREMENTS AND OVERHAUL SCHEDULE

1. To comply with 14 CFR 23.1529, continue the new divan and restraint system on the same inspection and maintenance schedule used per the applicable Hawker Beechcraft Maintenance Manual for seats.
 - a. The new divan installation requires no service other than inspection at normal Phase 4 inspection schedule of 800 hours or 24 months whichever occurs first.
 - b. The safety belts require no service other than inspection at normal inspection interval of 200 hours or annually.
 - c. Perform a detailed visual inspection of each bottom and back cushion and cover to detect apparent or obvious defects, deterioration in the form of wear, tears, rips, punctures or irregularities that cause the cushion assembly to become worn or distorted. Replace the cushion assembly if this cover does not fit properly or the cushion develops a "lumpy" or irregular feel.
 - d. Perform a detailed visual inspection of each divan frame assembly including weld joints, diaphragm, fasteners and anchors, track fittings, and restraint systems to detect apparent or obvious defects, corrosion, cracks, large deformations (permanent deformation in frame tubes more than $\frac{1}{4}$ the overall thickness of the tube diameter), irregularities that cause the frame assembly and/or anchor/fitting to become distorted and not fit into the intended seat track/anchor locations. If deformities are found the divan frame assembly must be removed from the aircraft and returned to Aviation Fabricators for repair or replacement.

2. Inspection Time Limit for 3 Place Side Facing Divan Assembly Installations:

800 hour inspection or 24 months for the divan assembly
200 hour inspection or annually for the restraint systems

Task Code			Schedule	Date	Mech	Insp
AFI-100	a.	Inspect for damage to upholstery.				
AFI-101	b.	Inspect safety belts for wear, cuts, fraying, damage, and deterioration.				
AFI-102	c.	Inspect safety belt attachment fittings for wear and damage				
AFI-103	d.	Inspect foot fittings for damage, security, and function.				
AFI-104	e.	Inspect seat frame for damage, and corrosion.				
AFI-105	f.	Inspect overall seat for fit and function.				

A. The new divan and restraint system on the same inspection and maintenance schedule used per the applicable Hawker Beechcraft Maintenance Manual for seats.

3.0 DIMENSION AND ACCESS

The installation of the divan does not change the dimensions of the aircraft or alter the access to any existing aircraft system.

4.0 LIFTING AND SHORING

No change.

5.0 LEVELING AND WEIGHING

Divan (Includes Restraints, No Upholstery)	= 22 lbs
Drawers (Includes hardware and slides)	= 8 lbs each
Maximum Allowable Seat Weight w/ Seat Bottom Cushion (Not including the placarded drawer contents weight)	= 135 lbs

6.0 TOWING AND TAXIING

No change.

7.0 PARKING AND MOORING

No change.

8.0 PLACARDS AND MARKINGS

Up to 3 placards are required in conjunction with this modification:

1. A placard stating “to install harness over seat occupant’s fwd shoulder” is sewn on to restraint system part numbers 3093-2-061-2396 and should be legible and easily viewed by the seat occupant.



Figure 8.0A

2. Drawer placard part number 15-0025 must be installed at the top of the face of the drawer where visible when open or closed.

**MAXIMUM WEIGHT OF 20 LBS
DRAWER MUST BE STOWED
DURING TAKE-OFF AND LANDING**

Figure 8.0B

9.0 SERVICE INFORMATION

Typical Divan Service Instructions:

A. Upholstery Cleaning:

Divan Service Instructions

1. Remove seat back and seat bottom cushion assemblies from sidewall and divan top.
2. If possible dry clean fabric cushions.
3. Clean the cushions and drawers in accordance with instructions issued by the company responsible for the upholstery covering so that knowledge of the upholstery material's fire retardant properties are known and will not be compromised.
4. Clean and inspect restraint system for damage, fraying, cuts or seam deterioration.
5. Inspect all attachment fittings and replace if necessary.
6. Inspect overall seat for fit and function.

Typical Divan Maintenance Instructions:

Divan Assembly

The divans are self contained complete assemblies that mount to the existing aircraft cabin seat track using standard fittings in accordance with floor plans approved per the airplane flight manual or a separate installer obtained FAA field approval. Refer to Figure 1.0A.

Divan Installation:

The installation of the divan requires (1) setting the divan into the correct location, and (2) sliding the divan forward or aft on the track to allow the hold down fitting keepers to lock in place in the existing seat track.

Divan Removal:

Removal of the divan assembly requires (1) lifting the attaching hold down fitting keepers, (2) sliding the divan forward or aft to remove the hold down fitting studs from locking into the seat track, and (3) lifting the divan from its previous location.

Cushions

Seat back and seat bottom cushion assemblies are removed by simply pulling the cushion inboard away from the Velcro on the sidewall or up away from the Velcro on the pan of the divan assembly, respectively. The seat bottom and seat back cushions should weigh no more than 10 lbs each. All covering and upholstery materials must comply with 14 CFR 23.853 as stated on the installation instructions, AF-153. Refer to Figure 1.0D for Cushion Assembly Reference.

Forward Bulkhead Pad

Per the installation instructions, AF-132, of the divan assembly, if the divan is installed next to a forward bulkhead, the bulkhead must be properly padded to comply with 14 CFR 23.785. Figure 1.0E

Oxygen Dispensing Unit Availability

Per the installation instructions, AF-132, of the divan assemblies, the divan installation must comply with 14 CFR 23.1441. Each dispensing unit must be capable of being readily available to be placed into position on the face of the seat occupant.

B. RECOMMENDED OVERHAUL PERIODS

No additional overhaul time limitations.

10.0 AIRWORTHINESS LIMITATIONS

The Airworthiness Limitations section is FAA approved and specifies maintenance required under Sec. 43.16 and 91.403 of the Federal Aviation Regulations unless an alternative program has been FAA approved.

There are no Airworthiness Limitations to the aircraft with the addition of the 3 place side facing divans installed by this STC.

11.0 TROUBLESHOOTING

Refer to the existing Aircraft Maintenance Manual for troubleshooting the 3 place divan installations that are required beyond the information found on the installation drawing AF-132.

For replacement parts or repair of damage parts contact Aviation Fabricators at (660) 885-8317.

Troubleshooting this installation should only be accomplished by FAA approved repair stations with the appropriate ratings or appropriately rated operator/individuals, with required test equipment and service data.